

PORTABLE SCREW COMPRESSOR PDS185S



Control panel



Main Improvements:

◆ Superior Serviceability

- Newly-designed GULL-WING door - Easiest access to interior inspection and maintenance.
- Filter Cartridge type Separator allows easiest replacement.

◆ Main Components - Maintenance-Free

- New Piston type Automatic-Relief Valve has no diaphragm. Thus servicing of diaphragm is not required any longer.
- Pressure Adjustment Regulator has become smaller and has no diaphragm which need be replaced. It is not necessary to replace diaphragm any longer.

◆ Smooth and Easy Cleaning

- Fittings of oil piping connection have been designed to be O-Ring seat type to eliminate oil leakage.
- Radiator and oil cooler are combined in form of one piece panel so that it provides much more smooth and easier cleaning of radiator and oil cooler.

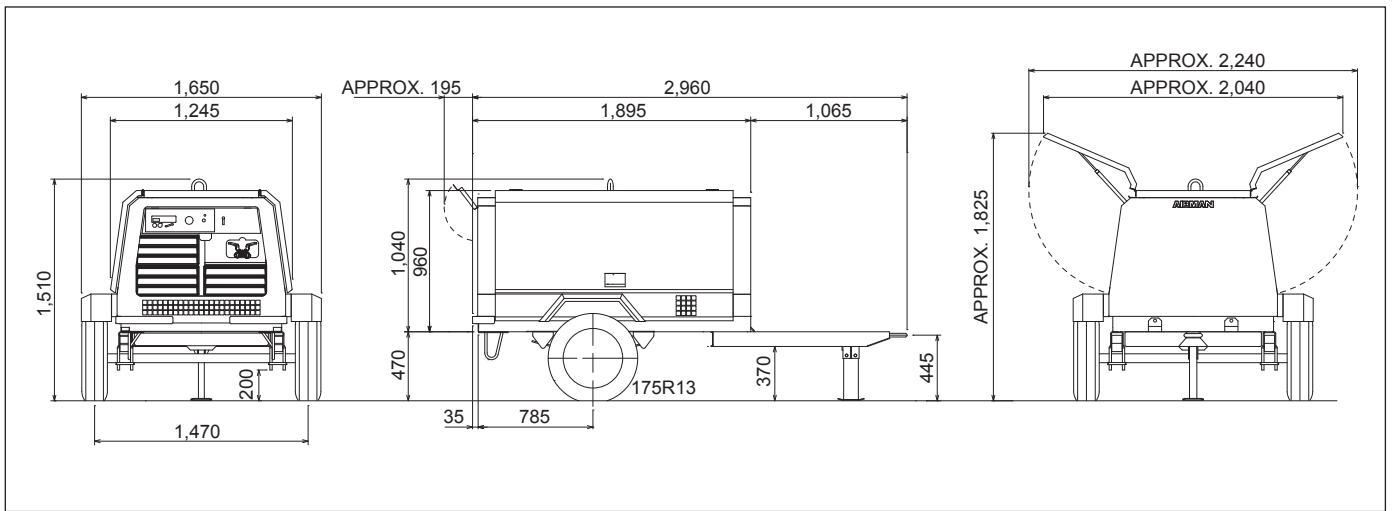

SPECIFICATIONS PDS185S-6C2

COMPRESSOR

Type	Rotary twin screw, single stage, oil-cooled
Free air delivery	5.2 m ³ /min(185 cfm)
Working pressure	0.69MPa(7 kgf/cm ² G)(100 psi)
Unloader	Suction port closing in connection with stepless speed regulator
Lubrication system	Forced lubrication by compression pressure
Driving system	Direct coupling with gears
Oil cooling	Air-cooled
Air cleaner	Dry paper filter type

DIESEL ENGINE

Model	YANMAR 4TNV88-BDHS
Type	Water-cooled, 4-cycle, direct injection type
No. of cylinders	4
Cyl. bore X stroke	88 mm x 90 mm
Total displacement	2.189 liters
Compression ratio	19.0 : 1
Rated output	36.4 kW/3,000 min ⁻¹ (49.5 PS/3,000 rpm)
Middle torque	140.8 Nm/approx. 1,800 min ⁻¹ (14.4 kgf-m/approx. 1,800 rpm)
Injection pump	Yanmar VE pump type
Governor	Centrifugal, all-speed
Alternator	DC 12 V, 40 A
Starting motor	DC 12 V, 1.7 kW
Battery	80D26R-MF(NX110-5MF)x1 pc.
Air cleaner	Dry type
Fuel tank capacity	90 liters
Engine oil capacity(including oil cooler)	7.4 liters
Coolant capacity(including engine radiator)	5.8 liters
Compressor oil capacity(including receiver tank & oil cooler)	15 liters

OIL SEPARATOR-RECEIVER TANK

Type	Vertical, cylindrical, full-welded
Shell dia.	φ226.4 mm
Shell length	594 mm
Capacity	0.021 m ³
Max. working pressure	1.38 MPa(14.1 kgf/cm ² G)
Hydraulic test pressure	1.8 MPa(18.4 kgf/cm ² G)
Air outlet valve	20 A x 2 pcs.

INSTRUMENTS & GAUGES

EMERGENCY STOP DEVICES

Engine oil pressure switch , Delivery air temperature switch , Engine coolant temperature switch , Disconnected of delivery air temperature sensor , Disconnected of engine coolant temperature sensor

WARNING LAMP

For engine coolant temperature rise
For delivery air temperature rise
For battery charging
For fuel level down

OPERATING LAMP

Glow lamp

GAUGES

Pressure gauge , Fuel gauge

MONITOR INDICATOR

Delivery air temperature , Engine coolant temperature , Engine speed(rpm) , Hour meter

OPERATING SWITCH

Starter switch , Starting unloader valve , Monitor change switch , Error code indication switch

WEIGHT

Dry weight	860 kgs
Operating weight	960 kgs

SAFETY

- Operate safely in accordance with proper operation manual.
- To prevent trouble and accidents, perform daily and preventive maintenance checks without fail.



ISO9001 : JQA-0581
ISO14001 : JQA-EM4670